

FVR SERIES

Semi-hermetic screw compressors for refrigeration

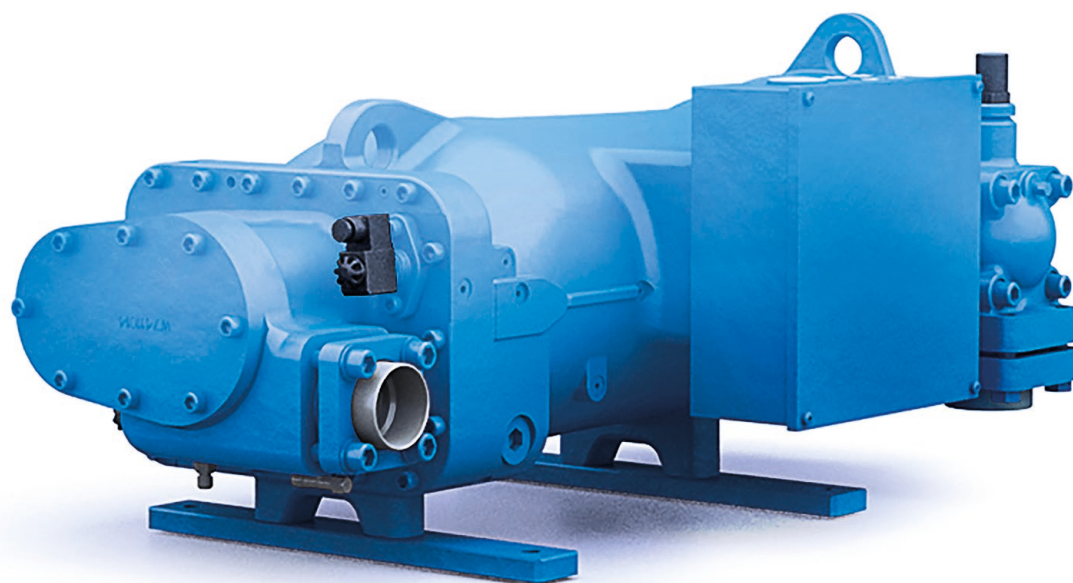

50Hz & 60Hz

frascold[®]
Blue is better

INDEX

4	About the Company
5	Segments and Solutions
6	Product Information
16	Technical Data and Operating Limits
22	Technical Drawings and Dimensions
31	Contact us

ABOUT THE COMPANY

Frascold manufactures over 70,000 screw and reciprocating compressors a year. Our 53,000 m² factory outside of Milan (Italy) houses our advanced engineering, manufacturing and testing facilities. More than 200 employees work in the Headquarters and in the Subsidiaries based in the United States, China and India, with distribution partners and service centers in 86 countries.

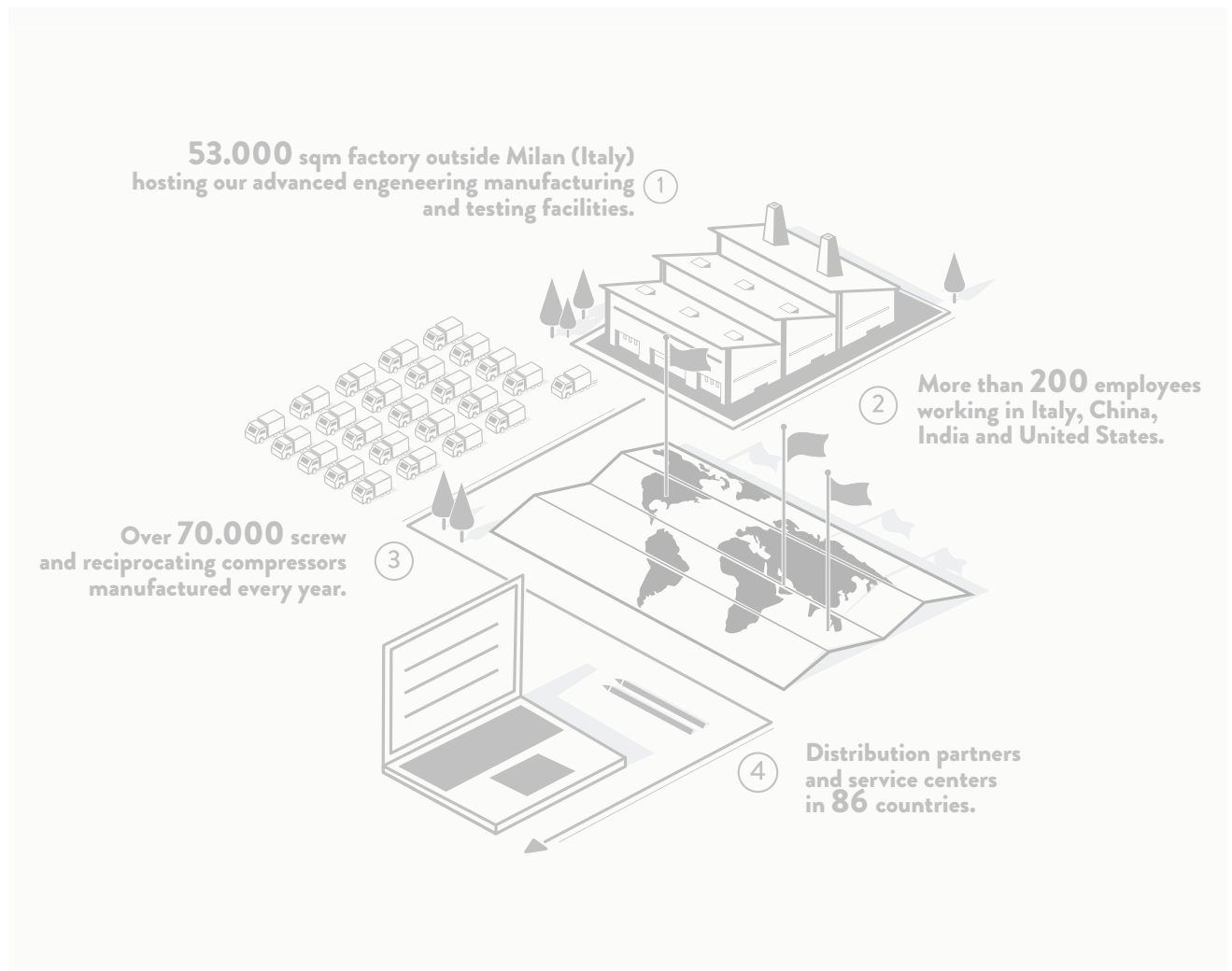

More than 85 years ago Frascold was born as a small family owned Company developing solutions in refrigeration and conditioning industry. Today we invest more and more in people, products, technologies and services aiming to become the best partner for our Customers and the touchstone for the market.

GIUSEPPE GALLI - Frascold Executive Managing Director

SEGMENTS



SOLUTIONS

Cooling capacity range @50Hz & @60Hz

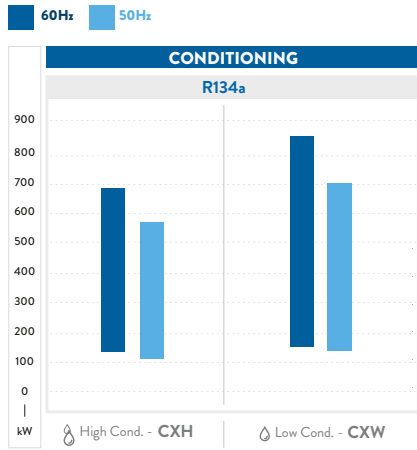

Testing conditions data reference:
 H. Cond.: evap. T. +2°C; cond. T. +50°C; superheating 10K; subcooling 5K
 L. Cond.: evap. T. +3°C; cond. T. +38°C; superheating 10K; subcooling 5K

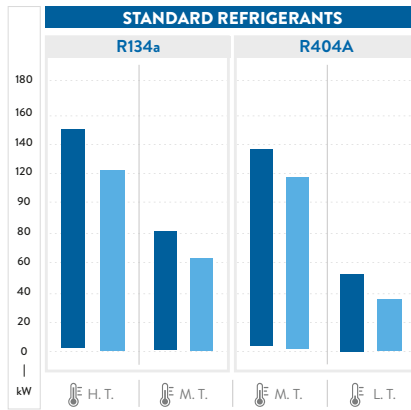

Testing conditions data reference:
 H.T.: evap. T. +5°C; cond. T. +50°C
 M.T.: evap. T. -10°C; cond. T. +45°C
 L.T.: evap. T. -35°C; cond. T. +40°C

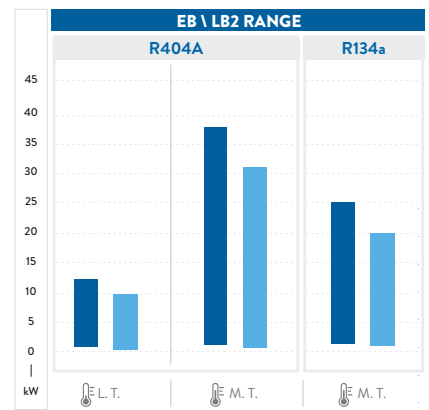

Testing conditions data reference:
 M.T.: cooling capacity @32°C ambient T.; evap. T. -10°C
 L.T.: cooling capacity @32°C ambient T.; evap. T. -35°C

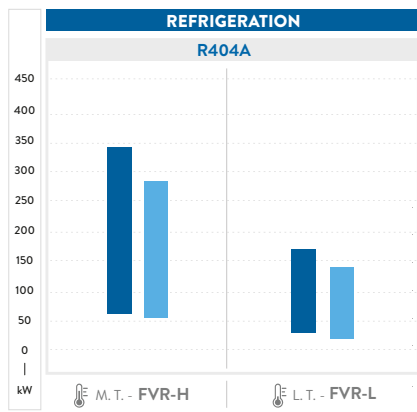

Testing conditions data reference:
 M.T.: evap. T. -10°C; cond. T. +45°C
 L.T.: evap. T. -35°C; cond. T. +40°C ECO

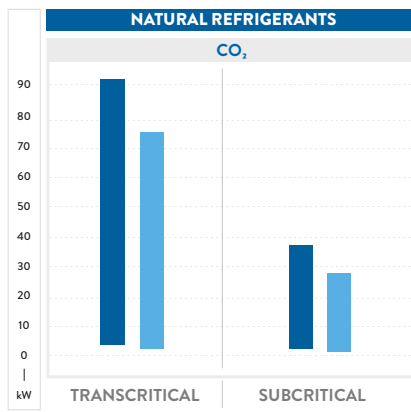

Testing conditions data reference:
 Transcritical: Evap. T. -10°C; Gas cooler out T. 33°C;
 Gas cooler pressure 83,7 bar; Superheating 10K;
 Subcritical: Evap T. -30°C, Cond. T. +10°C; Superheating 10K;

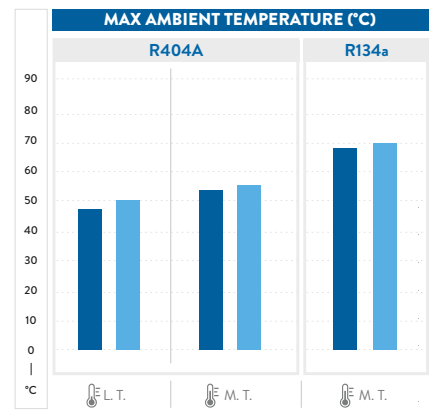

Testing conditions data reference:
 M.T.: evap. T. -10°C
 L.T.: evap. T. -35°C



FVR-H / L SCREW COMPRESSORS FOR REFRIGERATION

The latest addition to the Frascold family is the all new FVR-H and FVR-L Series screw compressor. This small-footprint machine, is the distillation of our many years of experience building screw compressors. Quiet, efficient, and reliable, the FVR Series is everything you have come to expect from Frascold. The FVR series consists of **37 models** ranging from 30-180 Hp and displacements of 120 to 540 m³/h. A broad refrigerant range includes **R134a, R404A, R507, R407A, R407F, R448A, R449A, and R290**. This series of compressors is ideal for many uses including industrial, pharmaceutical, retail, marine and heat pump applications.

FEATURES AND BENEFITS



Plug&Play: Easy installation & service



All models VFD compatible



High efficiency



Compact footprint



Refrigerants

HFCs, HFOs and natural refrigerants.



Silent operations

Perfect mechanical balancing means low vibrations, pulsations and noise.



Flexibility

The right compressor for any application: Commercial refrigeration, Air conditioning, Industrial refrigeration, Retail cooling systems, Pharmaceutical manufacturing, Liquid chillers, Process chillers, Marine cooling systems, Cryogenic systems & Heat Pumps.



Advanced protection systems (Optional)

CONFORMITY DECLARATION

Frascold Screw compressors for refrigeration are intended for installation in refrigeration systems. The machine or partly completed machines shall comply with local safety regulation and standards of the place of installation (within the EU according to the EU Directives 2006/42/EC Machinery Directive, 2014/68/UE Pressure Equipment, 2006/95/EC Low Voltage Directive). They may be put into operation only if the compressor has been installed in accordance with these assembly instructions.

Commissioning is only possible if the entire system into which it is integrated has been inspected and approved in accordance to the provisions of legal regulations.

The Manufacturer Declaration, describes the standards to be applied.

The Manufacturer Declaration of incorporation, according to the 2006/42/EC, is available at: www.frascold.it, documentation, manufacturer's declaration.

PERFORMANCE DATA FSS3 SOFTWARE

8

Please refer to our FSS3 to check performances of all our compressors.

- ① Operating limits
- ② Cooling capacity
- ③ All operating data with any kind of refrigerant
- ④ European standard EN12900 at 50Hz
- ⑤ Technical information
- ⑥ Drawings
- ⑦ Manuals
- ⑧ Catalogues and certifications

CONTROL PROTECTION DEVICE |

Standard compressor protection:

All the compressors are supplied complete with an **INT69 FRY** electronic protection module connected to a chain of PTC thermistors inserted into the electric motor, and a thermistor sensor positioned on the discharge temperature control output. If a problem is encountered, the module will shut the compressor down to prevent damage.

Optional compressor protection:

Optionally, all compressors can be equipped with the new **Kriwan INT69 FRYL® Diagnose** protection module. This adds data logging, diagnostic, and protection features that can improve reliability and service life of the compressor. Logged data can be used to aid in system optimization, identify problems and prevent malfunctions before they happen. The **INT69 FRYL® Diagnose** protection device has a dedicated connection port for the following compressor protection devices:

- Thermistor PTC (1, 2)
- Discharge temperature sensor (3, 4)
- Oil level check (5, 6)
- Oil filter clogging sensor (7, 8)
- Oil flowswitch (9, 10)



Protection features:

Data logged on the **INT69 FRYL® Diagnose** device can be downloaded via USB or DP-Modbus. This data can be used by technicians to correct system issues or conduct preemptive maintenance. The Kriwan software for reading data may be downloaded directly and free of charge from the website. In the event of a compressor malfunction, the device makes available the following features and data:

Safety Features

- Phase control
- Monitoring the number of start-ups
- Oil temperature check (and of discharge)
- Motor temperature check
- Oil level check
- Oil filter clogging check
- Oil flow check

Statistical Data

- Detailed list of the last 20 errors
- Number of on/off cycles
- Number of compressor start-ups
- Run times of compressor and accessories
- Number of start-ups over the last 7 days
- Maximum number of re-starts in an hour

ATEX |

The ATEX directive (2014/34/EU) is a certification for equipment and protective systems intended for use in potentially explosive atmospheres, caused by the presence of gases or solid dust. **Our complete range of reciprocating and screw compressors (CX and FVR) is 100% certified in category 3G: devices or protection systems that guarantee a very high level of protection Zone 2: an area where an explosive atmosphere may be present, but only in rare cases or for short periods.**

The compressor label includes the following ATEX assembly marking, usually placed on the wiring box:

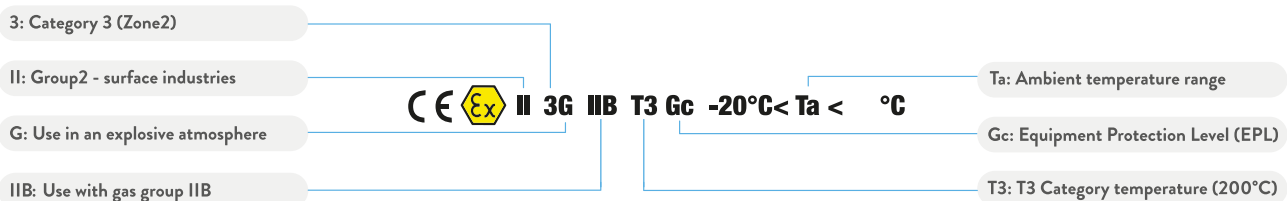

COOLING CAPACITY

Range @50Hz & @60Hz



LEGAL DISCLAIMER:

While Frascold has made every effort at the time of publication to ensure the accuracy of the information provided herein, product specifications and performances could be subject to change without notice.

You can find the most updated information in our Product Selection Software FSS3 at the link:

https://www.frascold.it/en/download/software/fss_3_frascold_selection_software

PRODUCT RANGE

FVR-H, FVR-L MODELS RANGE

40 - 180 HP

120 - 540 m³/h @50Hz | 144 - 648 m³/h @60Hz

FVR H SERIES

High &
Medium Temperature

26 Models

FVR L SERIES

Low Temperature

11 Models

30 - 160 HP

120 - 540 m³/h @50Hz | 144 - 648 m³/h @60Hz

MODEL DESIGNATION

Compressor

FVR - L - 50 - 160 AX

Series	
FVR	Semi-hermetic screw compressor
Application	
H	High/medium evaporating temperature
L	Low evaporating temperature
Motor Size	
Nominal power (HP)	
Displacement	
120÷540 m ³ /h at 50Hz	
Characterization Series	
Atex series	

INFORMATION PLATE

Manufacturer ATEX Certification Compressor model

Serial number
Manufacturing year
Maximum operating pressure
Maximum standstill pressure
Locked rotor current
PW Locked rotor current
Direct on line locked rotor current
Maximum operating current

frascold ®			Type	FVR-H-100-300AX	
			Nr.	HU000001	2021
Frequency/ Displacement/ Speed	Hz	Displ. m ³ /h	RPM	Max. Operating Disch. Pressure	bar 30
	50	300	2900	Max. Static Suct. Pressure	bar 20,5
	60	360	3500	II 3G Ex h IIB T3 Gc -20°C < Ta < +55°C	
Three-phase alternating current	3~				
Motor type	Volt	Hz	MRA	LRA	
Specified voltages	PW		PW	PWS	DOL
	380-420	50	183	488	767
Specified frequencies	440-480	60	183	488	767
Identification barcode		Identification code		Place of manufacturing	
Frascold S.p.A.		CFL10300HXU000001		MADE IN ITALY	

STANDARD EQUIPMENT AND OPTIONAL ACCESSORIES

Description	FVR	
	Std.	Opt.
Part winding (PWS) electric motor 380-420 V / 3 / 50 Hz (440-480 V / 3 / 60 Hz)	•	
Suction shut-off valves with soldering connections	•	
Discharge shut-off valves with soldering connections		•
Discharge flanges with soldering connections	•	
Integrated check valve and safety valve	•	
Steps capacity control and unloaded start	•	
IP65 terminal box	•	
Discharge temperature PTC sensor	•	
T00EC45B electronic protection module with manual reset (monitors motor windings, temperature, checks at start presence and correct sequence of phases and sense of rotation)	•	
Rotalock connection for oil injection	•	
Integrated oil filter and oil flow switch		
Oil injection kit: oil filter, oil flow switch, solenoid valve, oil sight glass [FVR] / Oil injection kit: solenoid valve, oil sight glass [FVR H / L 370 - 430 - 460 - 540]	•	
Nitrogen protective charge	•	
Packing ensuring proper handling and adequate protection	•	
Connection for ECO	•	
Special voltage for electric moto		•
Rubber vibration dampers (4 pcs)		•
Valve connection kit for ECO		•
Electronic Alarm Control Module for oil flow switch		•
Oil Filter Clogging Differential Pressure Switch (Electronic)		•
Bridges for DOL Start (STD for 120...160)		•
Special painting according to C5M painting requirements		•

CAPACITY REGULATION

Frascold Screw compressors capacity can be regulated with:

1. CAPACITY CONTROL (CC)
2. VARIABLE FREQUENCY DRIVE (VFD)

CAPACITY CONTROL (CC)

Under conditions of reduced thermal load, the compressor is capable of bringing the system to be cooled to the design temperature in a shorter time. In such a case, it is necessary to verify if the increased number of compressor start-ups (which derives from the shorter period of cooling) is compatible with the maximum that the compressor can support. The device used to control capacity, thus reducing the cooling capacity of the compressor, makes it possible to compensate for this situation and prevent the efficiency of the entire cooling system from being compromised. Checking the capacity requires the following functioning modes:

	Steps
FVR 120-160	75 / 100%
FVR 200-540	50 / 75 / 100 %

14

The step system for the FVR-H/L 370-430-460-540 series allows for obtaining a further partialisation step which corresponds with 25% of the refrigeration capacity available and is used exclusively as an unloaded start. The capacity check is carried out by the operation of three solenoids. The control sequence of the solenoids and the operational diagram are set out below.

Solenoid activation Diagram

Model Series	Capacity Control (1)			Start/Stop (2)
	Full load (100%)	1. Step (75%)	2. Step (50%)	
FVR-H/L 120-140-160	V1= ●	V1= ○	-	-
FVR-H/L 200-230-260 FVR-H/L 300-350-380	V1= ● V2= ●	V1= ● V2= ○	V1= ○ V2= ○	-
FVR-H/L 370-430-460-540	V1= ● V2= ○ V3= ○	V1= ● V2= ○ V3= ●	V1= ● V2= ● V3= ○	V1= ○ V2= ○ V3= ○

1: The effective capacity of the stages depends on the operating conditions.

2: The start/stop step can only be used during the start-up and stopping phases.

○ Coil de-energized

● Coil energized

VARIABLE FREQUENCY DRIVE (VFD)

All the compressors are designed for use with inverter technology and are suitable for operating within the frequency range (30÷70 Hz). In some conditions of use, a restriction on the range of frequency might apply. In particular, the upper frequency is dependent on the maximum operational current (MRA). For performance data at the various frequencies and the maximum limits under each condition, see Frascold selection software.

Calculate maximum frequency

Within the limits of use of each specific compressor and refrigerant for each work point, there is a maximum frequency not to be exceeded, which can be calculated using the following formula:

$f(\text{Max})$ = maximum possible frequency [Hz]

MRA = maximum operational current [A]

I_e = current absorbed at the work point at 50 Hz [A]

$$f(\text{Max}) = \frac{\text{MRA} \times 50 \text{ Hz}}{I_e}$$

Calculate corresponding capacity

The refrigeration capacity is calculated as a function of the frequency using the following formula:

$Q_0(f)$ = refrigeration capacity at working frequency [W]

f_a = actual frequency applied to the compressor [Hz]

$Q_0 50 \text{ Hz}$ = refrigeration capacity at 50 Hz [W]

$$Q_0(f) = \frac{f_a \times Q_0 50 \text{ Hz}}{50 \text{ Hz}}$$

TECHNICAL DATA AND OPERATING LIMITS

FVR Series

LEGAL DISCLAIMER:

While Frascold has made every effort at the time of publication to ensure the accuracy of the information provided herein, product specifications and performances could be subject to change without notice.

You can find the most updated information in our Product Selection Software FSS3 at the link:

https://www.frascold.it/en/download/software/fss_3_frascold_selection_software

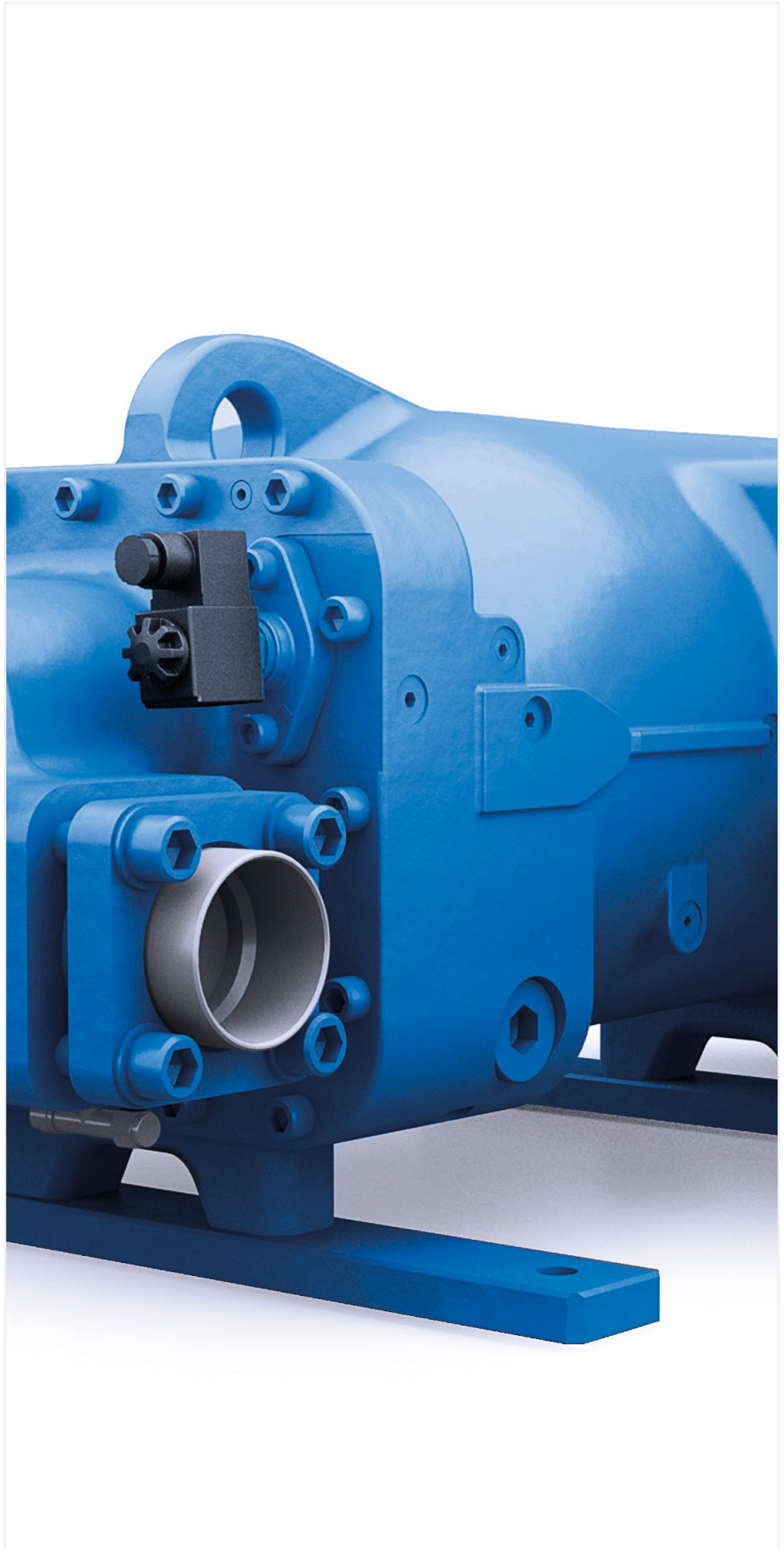

Standard motor Voltage - PWS 400 (+/-10%) V/3/50Hz // 460 (+/-10%) V/3/60Hz

Models	Motor Vers.	Displacement		Nominal power 50Hz [HP]	Partition steps [%]	MRA [A]	LRA, PW motor [A]	LRA, DOL motor [A]	Frequency min. [Hz]	Frequency max. [Hz]	Protection Index
		50Hz	60Hz								
		[m³/h]	[m³/h]								
FVR-H-30-120	1	120	144	30	75%	61	125	216	30	70	IP65
FVR-H-40-140	1	140	168	40	75%	68	171	294	30	70	IP65
FVR-H-50-160	1	160	192	50	75%	89	200	306	30	70	IP65
FVR-H-60-200	1	200	240	60	75% - 50%	101	262	425	30	70	IP65
FVR-H-70-230	1	230	276	70	75% - 50%	116	335	513	30	70	IP65
FVR-H-80-270	1	270	324	80	75% - 50%	184	373	600	30	70	IP65
FVR-H-90-300	1	300	360	90	75% - 50%	158	446	682	30	70	IP65
FVR-H-100-350	1	350	420	100	75% - 50%	169	522	799	30	70	IP65
FVR-H-110-370	1	370	444	110	75% - 50% - 25%	184	434	720	30	70	IP65
FVR-H-110-380	1	380	456	110	75% - 50%	201	570	872	30	70	IP65
FVR-H-115-430	1	430	516	115	75% - 50% - 25%	184	434	720	30	70	IP65
FVR-H-140-540	1	540	648	140	75% - 50% - 25%	245	587	921	30	70	IP65
FVR-H-125-460	1	460	552	125	75% - 50% - 25%	198	530	838	30	70	IP65
FVR-H-40-120	2	120	144	40	75%	68	171	294	30	70	IP65
FVR-H-50-140	2	140	168	50	75%	89	200	306	30	70	IP65
FVR-H-60-160	2	160	192	60	75%	108	254	389	30	70	IP65
FVR-H-70-200	2	200	240	70	75% - 50%	116	335	513	30	70	IP65
FVR-H-80-230	2	230	276	80	75% - 50%	184	373	600	30	70	IP65
FVR-H-90-260	2	260	312	90	75% - 50%	205	446	682	30	70	IP65
FVR-H-100-300	2	300	360	100	75% - 50%	169	522	799	30	70	IP65
FVR-H-115-350	2	350	420	115	75% - 50%	201	570	872	30	70	IP65
FVR-H-125-370	2	370	444	125	75% - 50% - 25%	218	530	838	30	70	IP65
FVR-H-125-380	2	380	456	125	75% - 50%	205	619	947	30	70	IP65
FVR-H-140-430	2	430	516	140	75% - 50% - 25%	245	587	921	30	70	IP65
FVR-H-160-460	2	460	552	160	75% - 50% - 25%	282	729	1114	30	70	IP65
FVR-H-180-540	2	540	648	180	75% - 50% - 25%	304	786	1209	30	70	IP65
FVR-L-30-120	-	120	144	30	75%	61	125	216	30	70	IP65
FVR-L-40-140	-	140	168	40	75%	68	171	294	30	70	IP65
FVR-L-50-160	-	160	192	50	75%	89	200	306	30	70	IP65
FVR-L-60-200	-	200	240	60	75% - 50%	101	262	425	30	70	IP65
FVR-L-70-230	-	230	276	70	75% - 50%	116	335	513	30	70	IP65
FVR-L-80-260	-	260	312	80	75% - 50%	184	373	600	30	70	IP65
FVR-L-90-300	-	300	360	90	75% - 50%	158	446	682	30	70	IP65
FVR-L-100-350	-	350	420	100	75% - 50%	169	522	799	30	70	IP65
FVR-L-110-380	-	380	456	110	75% - 50%	201	570	872	30	70	IP65
FVR-L-125-430	-	430	516	125	75% - 50% - 25%	198	530	838	30	70	IP65
FVR-L-160-540	-	540	648	160	75% - 50% - 25%	287	729	1114	30	70	IP65

Find the most updated information in our Product Selection Software FSS3 at the link : https://www.frascold.it/en/download/software/fss_3_frascold_selection_software

	Max. allowable standstill pressure	Max. allowable operative pressure	Suction Valve (SV)	Suction Valve (SV)	Discharge Bushing (DL)	Discharge Bushing (DL)	Net Weight	Models
	[bar]	[bar]	[mm]	[inch]	[mm]	[Inch]	[kg]	
	20,5	30	54	2" 1/8	42	1" 5/8	210	FVR-H-30-120
	20,5	30	54	2" 1/8	42	1" 5/8	223	FVR-H-40-140
	20,5	30	54	2" 1/8	42	1" 5/8	223	FVR-H-50-160
	20,5	30	80	-	54	2" 1/8	324	FVR-H-60-200
	20,5	30	80	-	54	2" 1/8	339	FVR-H-70-230
	20,5	30	80	-	54	2" 1/8	352	FVR-H-80-270
	20,5	30	80	-	67	-	430	FVR-H-90-300
	20,5	30	80	-	67	-	432	FVR-H-100-350
	20,5	30	105	4 1/8"	DN80		620	FVR-H-110-370
	20,5	30	80	-	67	-	435	FVR-H-110-380
	20,5	30	105	4 1/8"	DN80		623	FVR-H-115-430
	20,5	30	105	4 1/8"	DN80		632	FVR-H-140-540
	20,5	30	105	4 1/8"	DN80		626	FVR-H-125-460
	20,5	30	54	2" 1/8	42	1" 5/8	215	FVR-H-40-120
	20,5	30	54	2" 1/8	42	1" 5/8	223	FVR-H-50-140
	20,5	30	54	2" 1/8	42	1" 5/8	226	FVR-H-60-160
	20,5	30	80	-	54	2" 1/8	326	FVR-H-70-200
	20,5	30	80	-	54	2" 1/8	341	FVR-H-80-230
	20,5	30	80	-	54	2" 1/8	354	FVR-H-90-260
	20,5	30	80	-	67	-	432	FVR-H-100-300
	20,5	30	80	-	67	-	435	FVR-H-115-350
	20,5	30	105	4 1/8"	DN80		623	FVR-H-125-370
	20,5	30	80	-	67	-	437	FVR-H-125-380
	20,5	30	105	4 1/8"	DN80		632	FVR-H-140-430
	20,5	30	105	4 1/8"	DN80		749	FVR-H-160-460
	20,5	30	105	4 1/8"	DN80		648	FVR-H-180-540
	20,5	30	54	2" 1/8	42	1" 5/8	210	FVR-L-30-120
	20,5	30	54	2" 1/8	42	1" 5/8	218	FVR-L-40-140
	20,5	30	54	2" 1/8	42	1" 5/8	223	FVR-L-50-160
	20,5	30	80	-	54	2" 1/8	324	FVR-L-60-200
	20,5	30	80	-	54	2" 1/8	339	FVR-L-70-230
	20,5	30	80	-	54	2" 1/8	352	FVR-L-80-260
	20,5	30	80	-	67	-	430	FVR-L-90-300
	20,5	30	80	-	67	-	432	FVR-L-100-350
	20,5	30	80	-	67	-	435	FVR-L-110-380
	20,5	30	105	4 1/8"	DN80		625	FVR-L-125-430
	20,5	30	105	4 1/8"	DN80		645	FVR-L-160-540

OPERATING LIMITS

Diagrams published in this catalog are to be considered as a general diagram for the full range of semi-hermetic reciprocating compressors. For specific model and refrigerant performance data, please use the **FSS.3 Frascold Selection Software** available for free download at www.frascold.it.

Diagrams assume a full compressor load with a power supply frequency of 50 Hz. Performance displayed for R134a, R404A, R507A, R448A, R449A, R407F, R407A, and R290. Data on other refrigerants available on request. Capacities are shown in accordance with European EN12900 standard and at 50Hz operation. To calculate capacity in other conditions and at 60 Hz, please use the Frascold Selection Software (download free at frascold.it).

R134a

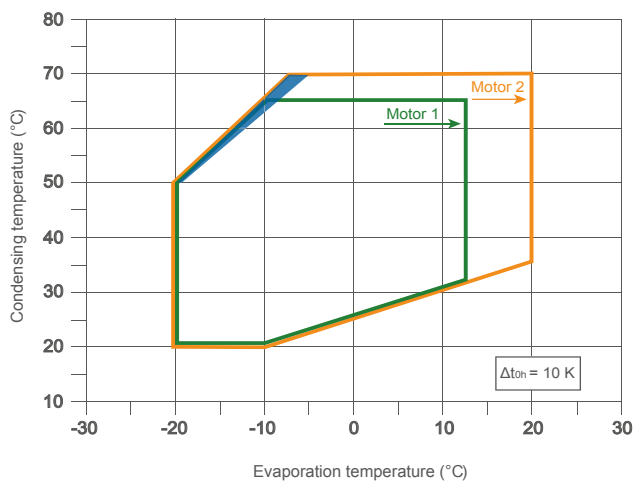

Standard application diagram

Motor size 1 - 2
Compressor capacity 100%
Overheating = 10K

20

R404A - R507A

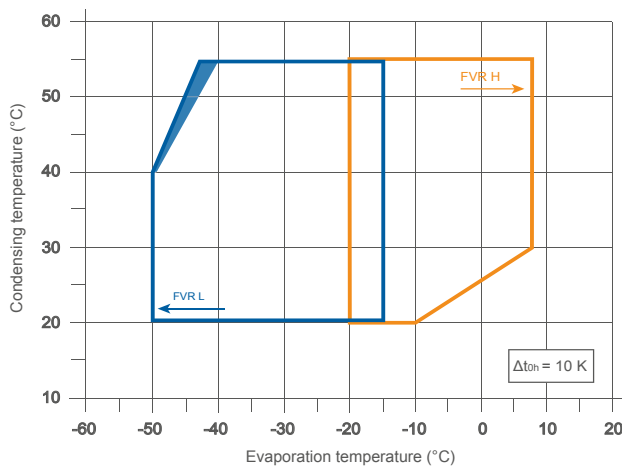

Standard application diagram

FVR H/L
Compressor capacity 100%
Overheating = 10K

■ For operation in this zone, please contact Frascold.

R448A - R449A

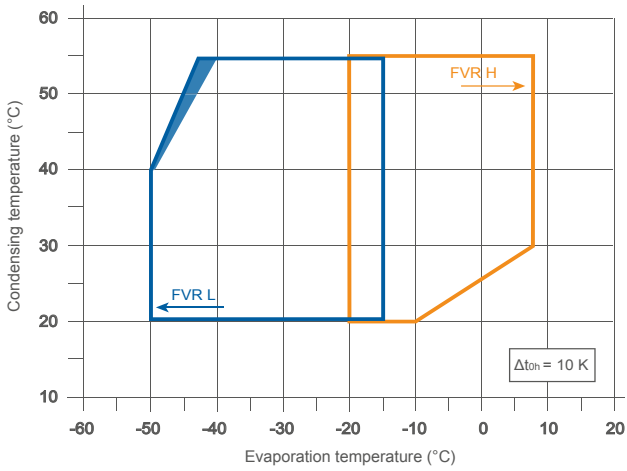

Standard application diagram

FVR H/L

Compressor capacity 100%

Overheating = 10K

■ For operation in this zone, please contact Frascold.

R407F - R407A

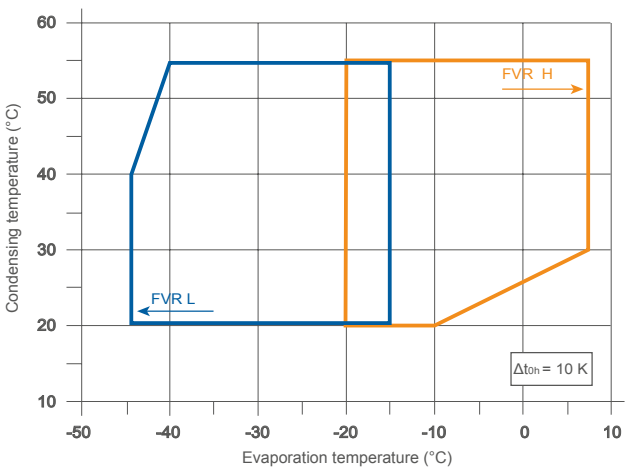

Standard application diagram

FVR H/L

Compressor capacity 100%

Overheating = 10K

R290

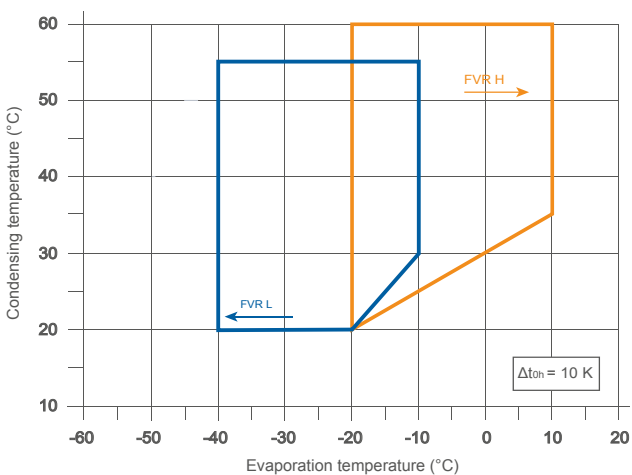

Standard application diagram

FVR H/L

Compressor capacity 100%

Overheating = 10K

TECHNICAL DRAWINGS AND DIMENSIONS

22

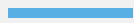

FVR Series

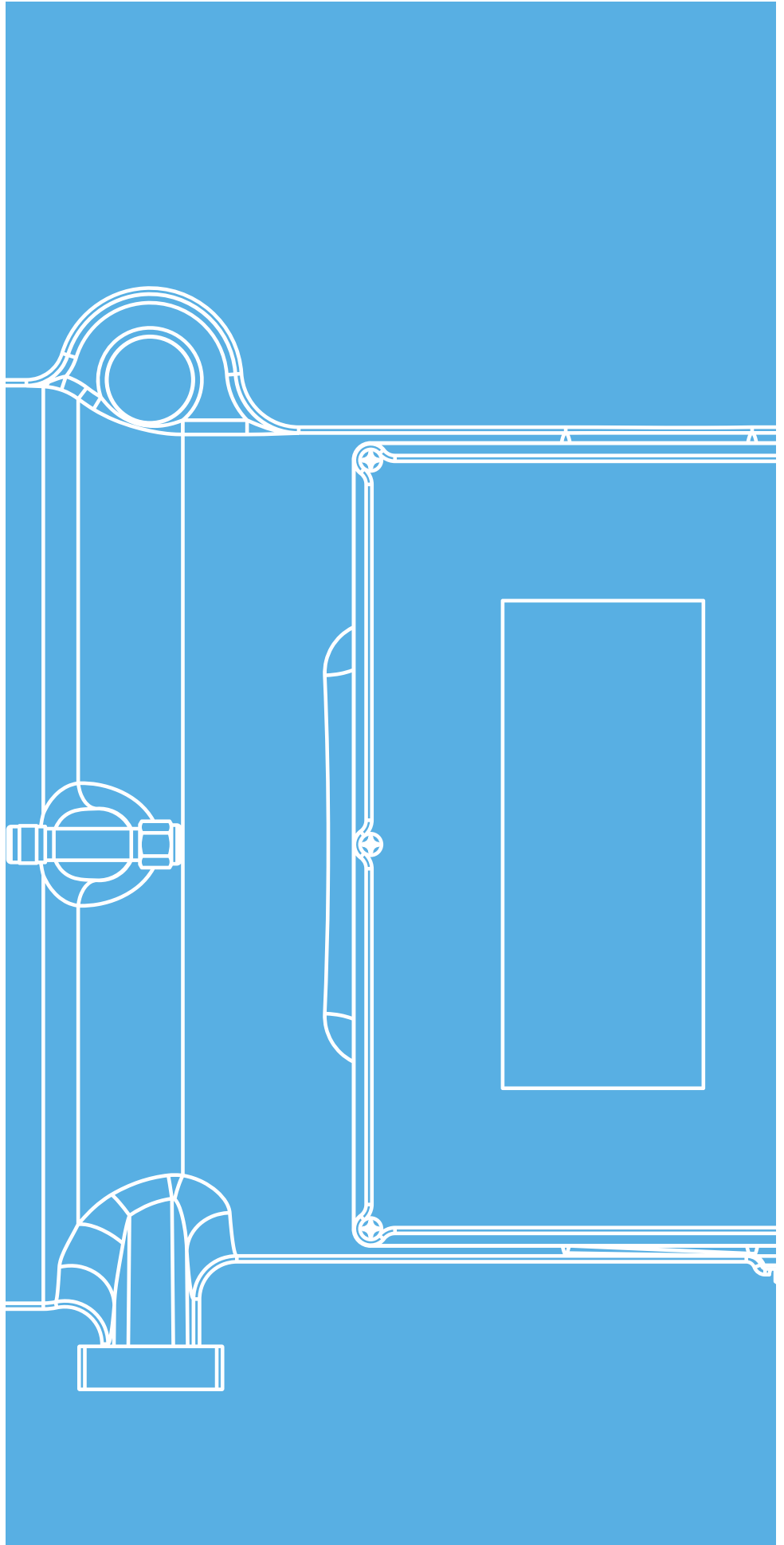
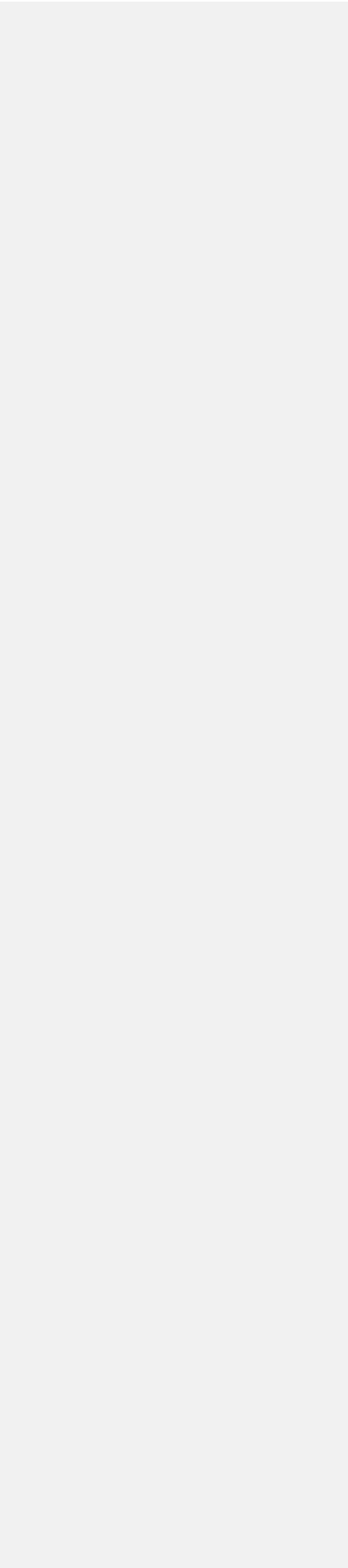

FVRH/L 120 - 140 - 160

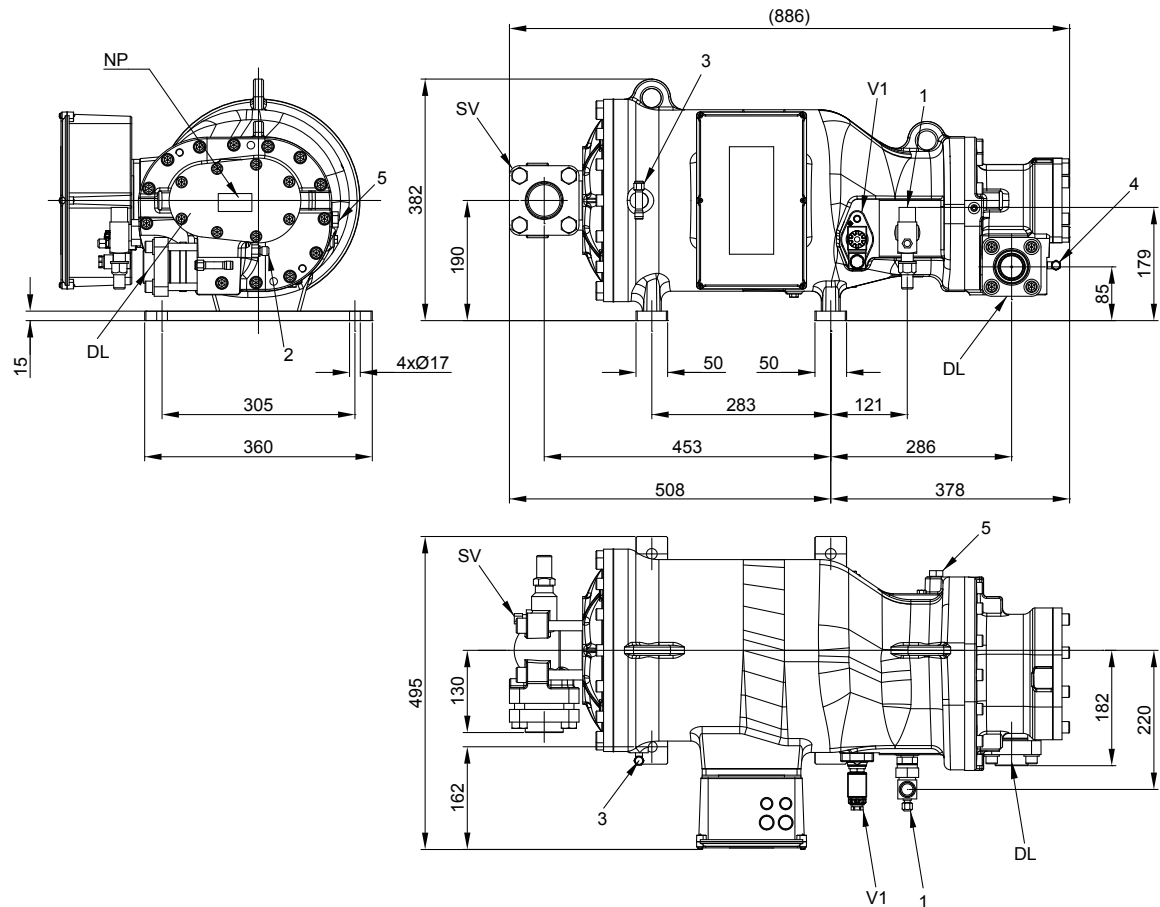

1	Oil return connection	
2	Discharge temperature sensor	
3	Low pressure connection	
4	High pressure connection	
5	Connection for ECO	1/2" SAE
V1	Capacity control valve (step 1)	
SV	Suction valve	2-1/8" - 54,0 mm
DL	Discharge valve	1-5/8" - 42,0 mm
NP	Information plate	

Dimensional drawing

FVRH/L 200 - 230 - 270

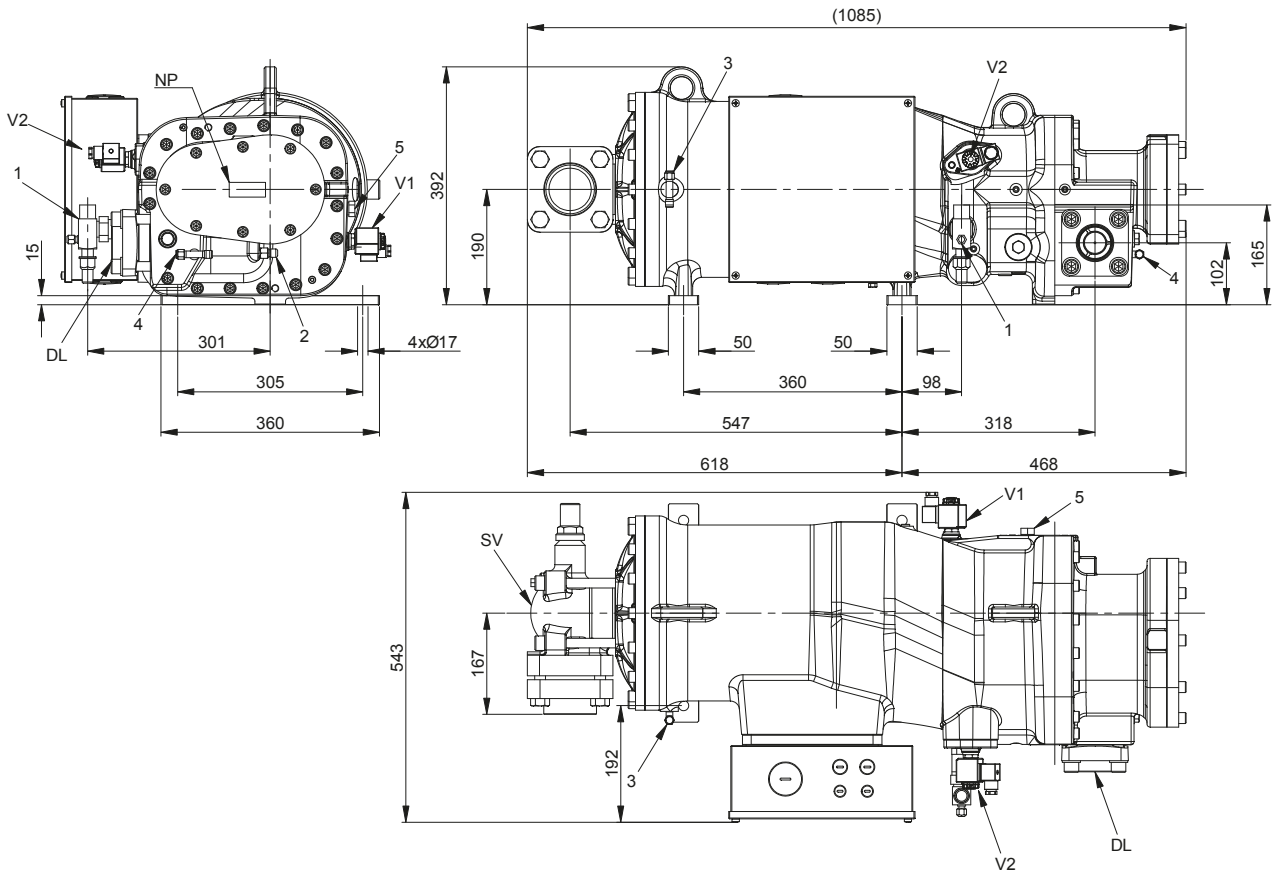

25

1	Oil return line connection	
2	Discharge temperature sensor	
3	Low pressure connection LP	
4	High pressure connection HP	
5	Connection for ECO	
V1	Capacity control valve	
V2	Capacity control valve	
SV	Suction valve	3-1/8" - 80 mm
DL	Discharge bushing	2-1/8" - 54 mm
NP	Information plate	

FVRH/L 90 - 270

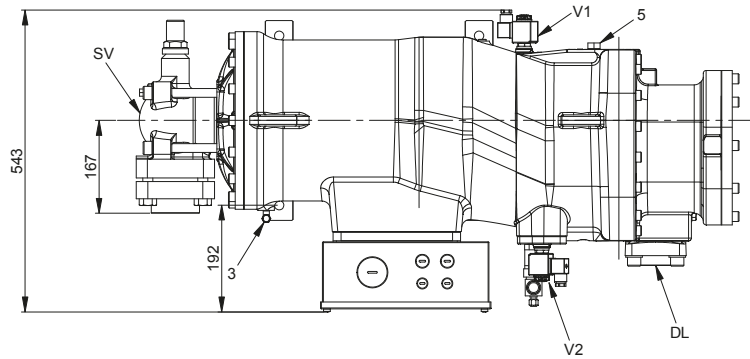
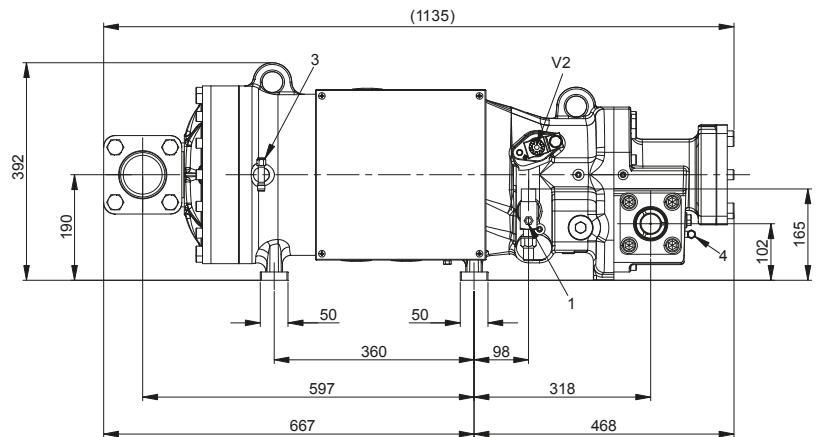
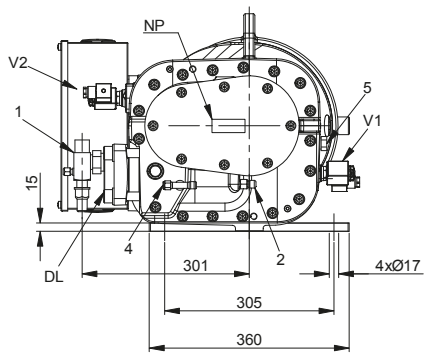

1	Oil return line connection	
2	Discharge temperature sensor	
3	Low pressure connection LP	
4	High pressure connection HP	
5	Connection for ECO	
V1	Capacity control valve	
V2	Capacity control valve	
SV	Suction valve	3-1/8" - 80 mm
DL	Discharge bushing	54 mm
NP	Information plate	

FVRH/L 300 - 350 - 380

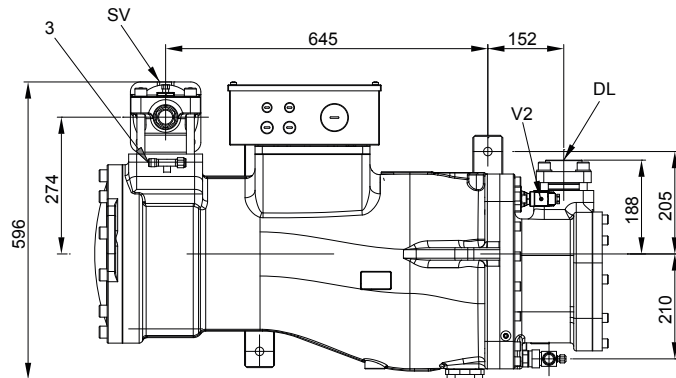
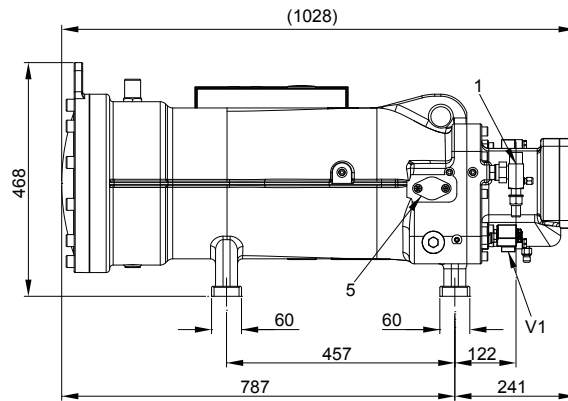
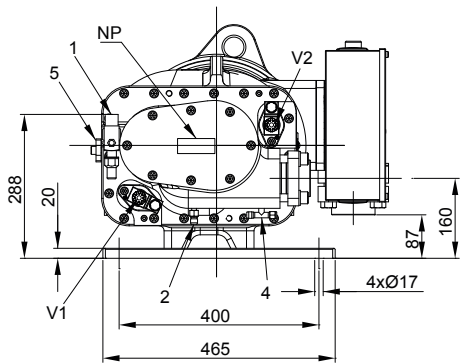

1	Oil return line connection	
2	Discharge temperature sensor	
3	Low pressure connection LP	
4	High pressure connection HP	
5	Connection for ECO	
V1	Capacity control valve	
V2	Capacity control valve	
SV	Suction valve	3-1/8" - 80 mm
DL	Discharge bushing	67 mm
NP	Information plate	

FVRH/L 370 - 430 - 460 - 540

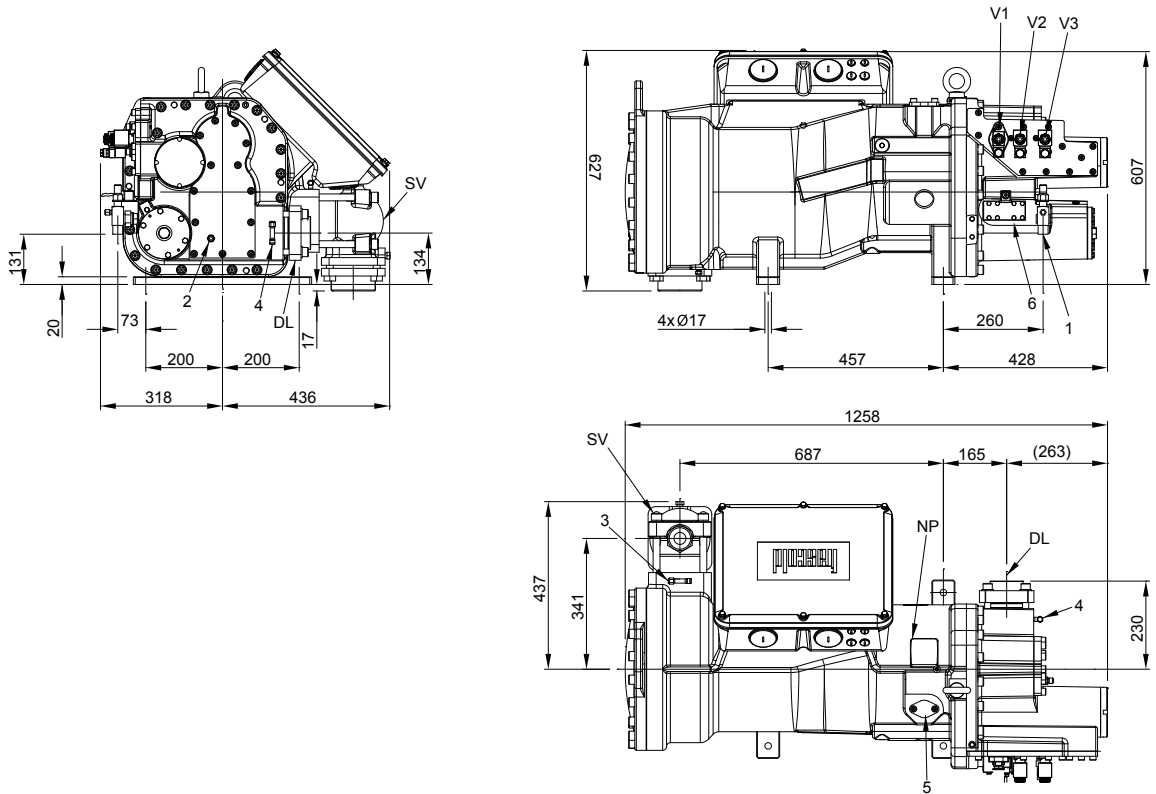

1	Oil return line connection	
2	Discharge temperature sensor	
3	Low pressure connection LP	
4	High pressure connection HP	
5	Connection for ECO	
V1	Capacity control valve	
V2	Capacity control valve	
SV	Suction valve	4-1/8" - 105 mm
DL	Discharge bushing	80 mm
NP	Information plate	

OIL INJECTION KIT

- The standard Frascold oil injection kit includes:
- Oil filter
 - Flowswitch with electronic control module
 - Solenoid valve
 - Oil flow sight glass

Oil circuit diagram for FVR-H/L-370-430-460-540

In the FVR Models, the flowswitch and the oil filter are integrated with the compressor.

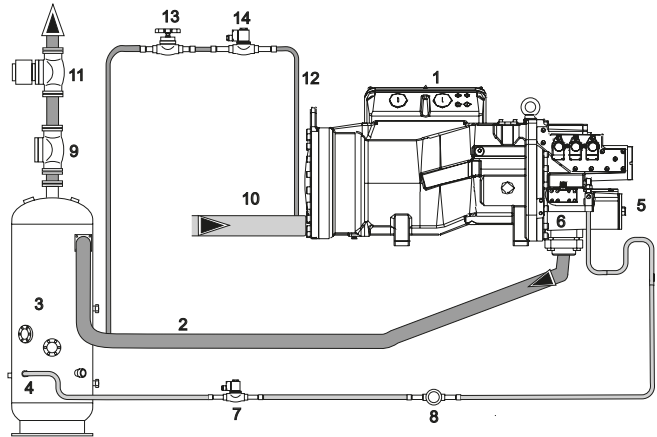

Oil circuit diagram for all other models.

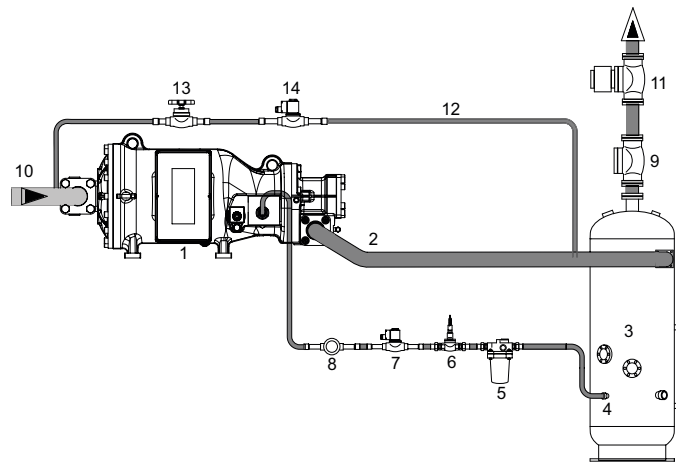

1	Compressor
2	Discharge line
3	Remote oil separator with thermostat, resistance and level detector
4	Oil return line to the compressor
5	Oil filter
6	Oil flowswitch
7	Solenoid valve
8	Oil sight glass
9	Check valve
10	Suction line
11	Discharge pressure regulation valve
12	External equalization line
13	Shut off valve
14	Solenoid valves

CONTACT & SUBSIDIARIES





HEADQUARTERS & PRODUCTION PLANT

FRASCOLD SPA - ITALY, MILAN

Via B. Melzi 105, 20027 Rescaldina (MI) Italy
Tel. +39 0331 742201 - Fax +39 0331 576102
frascold@frascold.it - www.frascold.it

SALES OFFICE

FRASCOLD CHINA

Frascold Refrigeration Co. Ltd
Room 612, 6th Floor,
Jinqiao Life Hub, No.3611
Zhangyang Road, New Pudong District,
Shanghai, CHINA
Ph. +86 021 58650192 / 58650180
Fax +86 021 58650180 - frascold.china@frascold.net

FRASCOLD INDIA PVT LTD

Frascold India Pvt Ltd.
A1/2/14/15, Gallops Industrial Park,
NH-8A, Sarkhej-Bavla Road, Rajoda,
Ahmedabad 382220 Gujarat. INDIA
Ph: +91 2717 685858,
sales@frascoldindia.com - www.frascoldindia.com

FRASCOLD USA

5343 Bowden Road, Suite 2
Jacksonville, FL 32216 - Ph. +1 (855) 547 5600 Office
info@frascoldusa.com - www.frascoldusa.com

CDU ASSEMBLY PLANT

Frascold India Pvt Ltd.
A172715716, Gallops Industrial Park,
NH-8A, Sarkhej-Bavla Rd, Rajoda,
Ahmedabad, Gujarat 382220

